

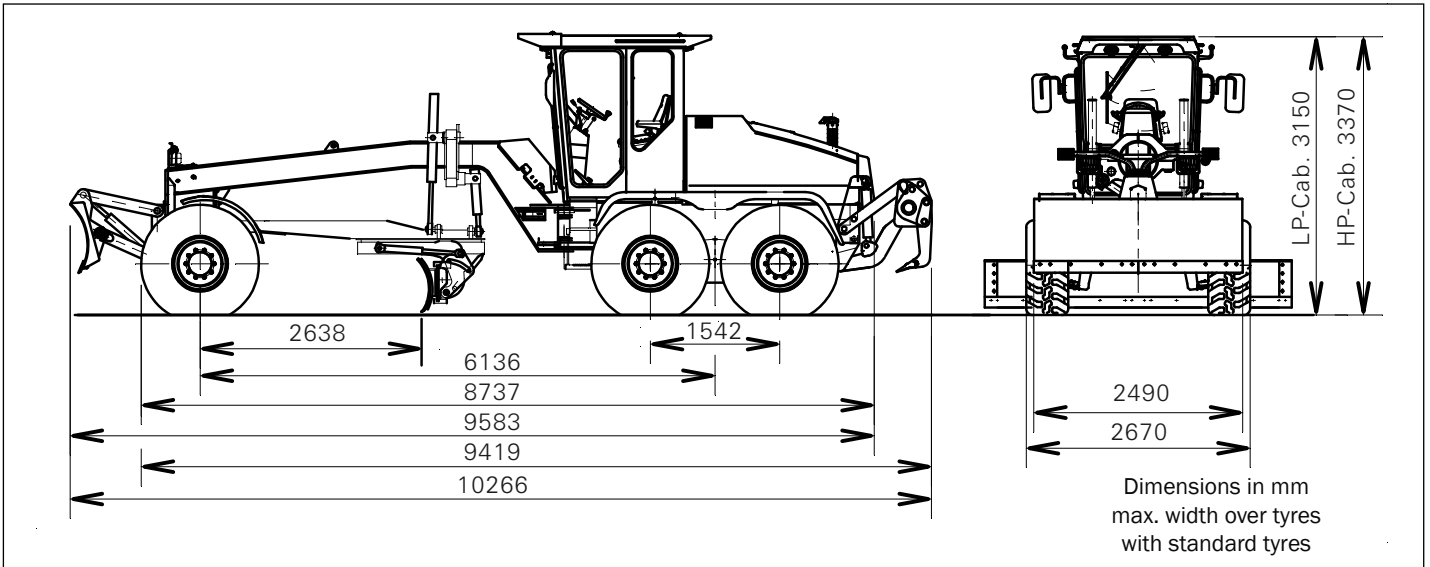

Motor Grader

BG 190 T-4 (6x4) / BG 190 TA-4 (6x6)



Engine Data

Make/Model	CUMMINS/diesel engine
Typ	4 cycle, direct injection, turbo charged, water-cooled,
Rated net horsepower (SAE J1995) at 2200 rpm	129 kW/176 HP
	at 2000 rpm 133 kW/181 HP
No. of cylinders	in line 6
Bore & stroke	107 x 124 mm
Displacement	6.7 litres

Engine equipped with a dual element, dry-type air cleaner with dust ejector. 24 volt starting and electrical system. 70 amp alternator and 24 volt starter with 3,7 kW (5,0 HP).
2 batteries 74 Ah each.



Speeds

(all wheel drive and rear axle drive systems)

Forward	km/h
1.	3.8
2.	6.6
3.	8.8
4.	15.4
5.	25.0
6.	40.0
Reverse	
1.	3.8
2.	8.8
3.	19.4

Acoustic back up alarm in reverse driving.



Operating Weight

Total weight	approx. 19000 kg
On rear wheels	approx. 13300 kg
On front wheels	approx. 5700 kg

Weights shown include cab, all operating fluids, HD rear ripper, front dozer blade.



Rear Axle

Oscillating tandem axle with axle insert.
No-Spin differential.
Multi-disc brakes in all four wheel hubs.
Parking brake at powershift transmission.



Tandems

Drive via roller chains.
Torsion-proof box sections.

Height	550 mm
Width	184 mm
Thickness of walls	20 mm
Wheel base	1542 mm
Oscillation	±15°
Ground clearance	480 mm



All Wheel Drive System

Hydrodynamic rear axle drive with 6-speed Ergopower transmission and torque converter as well as freely selectable microprocessor controlled hydrostatic front axle drive. Power train is controlled appropriate to tyre traction of front and rear wheels.



Rear Axle Drive System

Hydrodynamic rear axle drive with 6-speed Ergopower transmission (make ZF 6 WG) and torque converter.



Wheels & Tyres

Tyre size	17.5 R25 radial
Rim size	14.00 x 25/1.3



Brakes

Service brake

Dual-circuit, power-assisted, multi-disc oil-bath type, effective on four wheels. Includes reserve power and operator warning system

Parking brake

Independent electrically operated, acting on power shift. Hydraulic spring accumulated single disc type.



Front Axle

2 types are available

Oscillation	15° up and down
Steering angle	45°
Wheel lean	±17°
Ground clearance	591 mm

Non driven with wheel lean (T version)

Stable welded steel beam with wheel lean

Driven with wheel lean (TA version)

Stable welded steel beam with wheel lean and radial piston engines in wheel hubs, pulling power on surface conditions. Electronically adjustable (infinitely variable), possibility to fit in the hydraulic differential lock.



Steering

Hydraulic power steering.

Minimum turning radius without dozer blade	7500 mm
Minimum turning radius with dozer blade	8050 mm
Steering angle	45°



Frame

Front and rear frame sections connected with an adjustment free articulated pin.

Front: Fully welded box section

Minimum dimensions of box section	300 x 310 mm
Plate thickness	20 mm

Rear: Fully welded section

Dimensions (solid main bars)	270 x 90 mm
Hydraulic articulated frame steering (left & right)	30°



Circle (open version)

Hardened teeth, cut on inside of circle for maximum strength and minimum wear. The circle is held positively in place at four points by four clamps and guide shoes. The clamp and guide shoes are located where greatest loading occurs.

Diameter	1510 mm
Thickness	40 mm
Height	110 mm
Adjustable shoes and clamps	4



Circle Drive

Hydraulically driven worm gear transmission. Circle drive system fully protected against impact damage by an overload clutch.

Rotation	360°
----------	------



Drawbar

Y-shaped fully welded construction.

Dimensions (solid sections)	40 x 210 mm
-----------------------------	-------------



Moldboard (standard)

Moldboard (12 ft)	3660 x 660 x 20 mm (12' x 26,0" x 0,8")
Blade material	High carbon steel
Blade pull at a friction factor of 0.8	BG 190 T-4 96 kN BG 190 TA-4 121 kN



Blade Range

Reach outside tyres without articulation (RH&LH)	2485 / 1920 mm
Reach outside tyres with articulation (RH&LH) blade resting on levelled surface	3335 / 2770 mm
Blade side shift	1250 mm
Blade tilt range	31°- 74°
Bank sloping angle (RH&LH)	90°
Lift above ground	470 mm
Cut below ground	430 mm
Distance blade / front axle	2632 mm

All blade movements and positions can be controlled from the operator's seat.



Operator's Platform

Dimensions	
Width	1150 mm
Depth	1400 mm

Available with various options as listed under "Optional equipment", moldboard control acc. to EURO standard.



Capacities

Fuel	386.0 litres
Hydraulic oil	170.0 litres
Engine oil	18.0 litres
Ergopower transmission	34.0 litres
Axle drive, rear	13.5 litres
Planetary gears and brakes	16.0 litres
Tandem (2 x 21 litres)	42.0 litres
Circle drive	9.0 litres
Coolant	33.0 litres



Light Equipment

2 head lights at the front, every 2 indicator lights (including hazard warning lights) at the front and rear, 2 rear lights, 2 brake lights, 1 backup light plus every 2 working lights at the top and bottom at the front of the cab, 2 working lights at the top at the rear of the cab, and 2 tail lights on the sides.



Load-Sensing Hydraulics

The control valves of the working hydraulics may be actuated at a time and independent of each other. The load-sensing pump (axial piston pump) discharges only the required quantity of oil if a control valve is actuated. When hydraulic power is not required system pressure is only 24 bar and ensures low oil temperature und fuel saving.

Lock valves and brake valves prevent a cylinder drift under load.

Operating pressure	184 bar
Oil flow, max.	99l/min



Optional Equipment

Cab, standard, tiltable

Integrated ROPS/FOPS cab mounted on isolators to limit vibration and noise entering the cab. Excellent all-round visibility. Roomy and comfortable. Adjustable steering pedestal with EURO control lever arrangement. Interior of cab fully lined, floor covering. Tined safety glass windows, sliding doors left and right with lockable intermediate positions, fresh air heating with pre-filter, air circulation. Adjustable, mechanical spring mounted driver's seat with safety belt. One inside mirror and two folding outside mirrors.

Front window washer.
Wipers front and rear.
Blinds front and rear.

Height / Width / Depth	1980 / 1470 / 1700 mm
------------------------	-----------------------

Cab, low-profile, tiltable

Height / Width / Depth	1760 / 1470 / 1700 mm
------------------------	-----------------------

NAIS control panel (rods)

EP control panel (Joystick controls)

Air-condition for cab

Heatable rear view mirrors

Auxilliary heating

Beacon (orange)

Air-cushioned driver's seat

Recording speedometer

Cooling box

Stereo radio with CD-player

Sliding side windows

Protective grids for lights and cabin

Circle (closed version)

Hardened teeth, machine-cut on inside of circle for maximum strength and maximum wear. The circle is held positively in place by an adjustment-free roller bearing.

Circle diameter	1510 mm
Tool width	83 mm
Height	130 mm

Moldboard (13 ft) 3962 x 660 x 20 mm (13' x 26,0" x 0,8")

Moldboard (14 ft) 4267 x 660 x 20 mm (14' x 26,0" x 0,8")

Cover plate for upper guide rail of moldboard

Adjustable moldboard corner shoes, left or right

Moldboard extension, left or right (1 ft) 305 mm

Float position for both moldboard lift cylinders

Electric fuel pump with automatic switch-off

Towing device, tiltable

Wheels and tyres

Tyre size	14.00 x 24 diagonal
Rim size	10.00 x 24
Tyre size	17.5-25 diagonal
Rim size	14.00 x 25/1.3
	Other types on request.

Front dozer blade with position indicator, parallel guided

Width / Height	2490 x 780 mm
Cut below ground	170 mm
Lift above ground	505 mm
Weight	865 kg

V-scarifier between front axle and moldboard, 11 teeth

Ripping width	1310 mm
Ripping depth	240 mm
Lift above ground	300 mm
Weight	850 kg

Rear ripper with depth indicator, medium heavy, 4 teeth (max. 7)

Ripping width	2120 mm
Ripping depth	420 mm
Lift above ground	560 mm
Weight	804 kg

Heavy-duty rear ripper with depth indicator, 6 teeth

Ripping width	2120 mm
Ripping depth	270 mm
Lift above ground	570 mm
Weight	1529 kg

Push-Pull block, in front

926 kg

Front dozer blade, articulated

Mudguards

on front wheels

Mudguards

on rear wheels

Protective cover for powershift transmission

Biological Oil in hydraulic system

Articulation angle indicator

Fuel tank pump with automatic switch-off

Special paint

Ergopower transmission with torque converter and lock-up clutch

Tool kit, wheel chocks, warning triangle, fire extinguisher, first aid kit etc.

Automatic blade control

Various 2D / 3D / GPS systems

CE certificate

Speed limitation at 20 km/h possible

